

S22

PALLET INVERTERS

Pallet inverters are used for turning goods during the production process, for example, for turning coated boards upside down or for changing pallets. Furthermore, damaged goods in bottom positions can be exchanged without elaborate destacking and upstacking.

For very unstable goods we recommend the use of a lateral support arm. For palletless loading of containers, the pallet inverter can be combined with a load pusher.

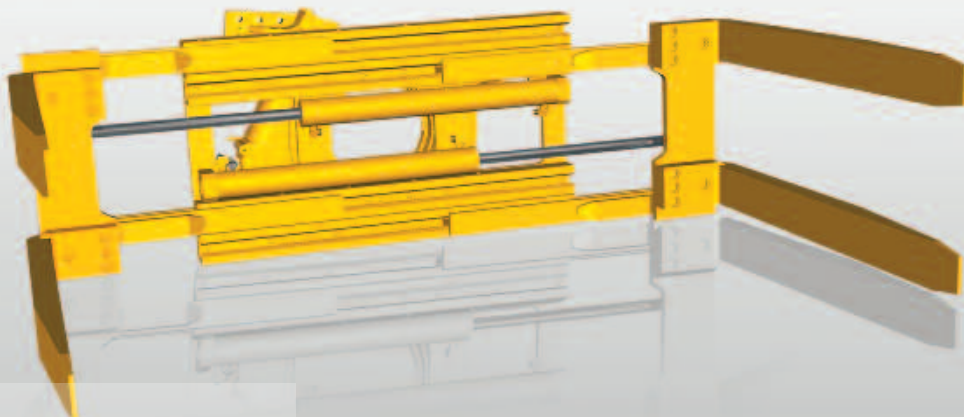

Pallet Inverters

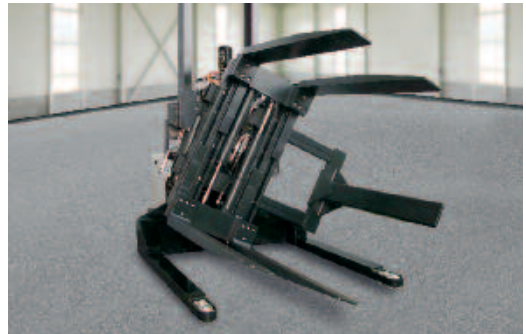
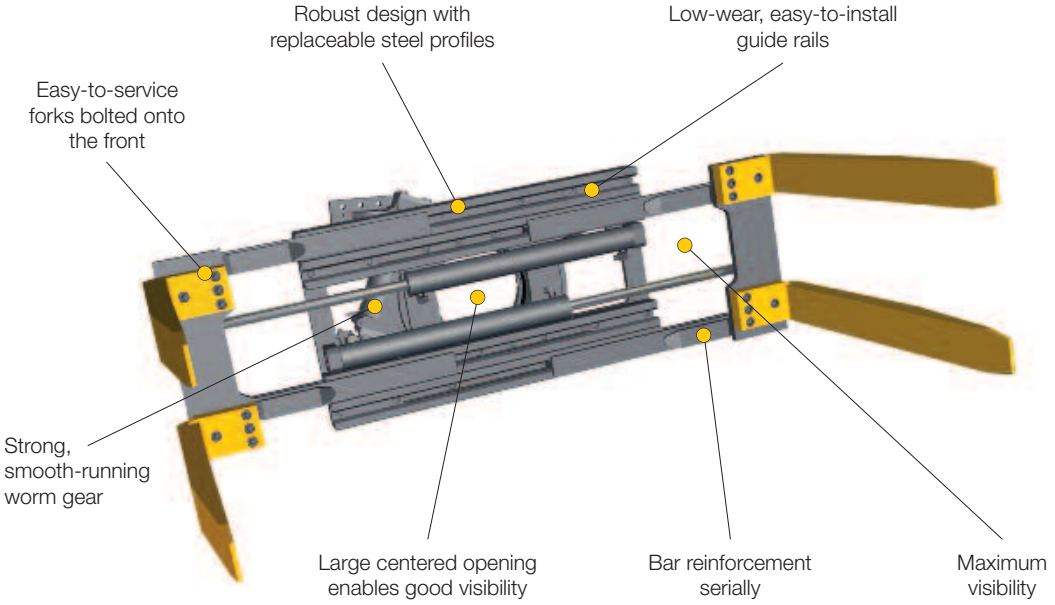

S22

Pallet Inverters

2 hydraulic functions

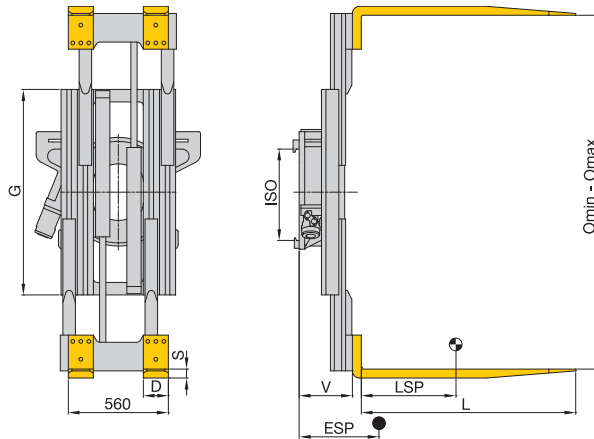

L = 1200 mm · Forks serially bolted on · Rotation range 360°

Model	Load capacity	LC (LSP)	ISO	Omin-Omax	G	D	S	V	CoG (ESP)	Weight	Price	Surcharge per 100 mm add. fork length	Surcharge per 100 mm add. opening range	Surcharge for sep. side-shift
	kg													
S 22 - PWG 12-360°	1000	600	2	560-1640	950	125	45	275	315	735				
S 22 - PWG 18-360°	1500	600	2	600-1800	1050	125	50	275	325	775				
S 22 - PWG 25-360°	2100	600	3	640-1980	1150	140	50	295	330	930				
S 22 - PWG 35-360°	3000	600	3	650-2100	1350	150	60	330	350	1240				

- Surcharge for adjustable pressure relief valve
- Surcharge for pressure gauge
- Surcharge for fixed lateral support arm
- Surcharge for solenoid valve with separate sideshift (utilization of only rotation/sideshift admissible)

- Adjustable lateral support arm on request.
- The opening range is measured at the fork back. Due to a prestress the opening range between the fork tips is correspondingly smaller.

Standard values for residual load capacity of lift trucks**

Pallet Inverters	S 22 -	PWG 12 -360°	PWG 18 -360°	PWG 18 -360°	PWG 25 -360°	PWG 25 -360°	PWG 35 -360°	PWG 35 -360°	PWG 35 -360°
Load capacity lift truck	kg	1500	2000	2500	3000	3500	4000	4500	5000/500
X*	mm	350	450	450	450	500	500	500	560
LC (LSP) = 500 mm	kg	760	1130	(1500)	1800	(2100)	2320	2700	(3000)
LC (LSP) = 600 mm	kg	700	1040	1420	1660	2060	2160	2510	2950

** The load capacity applies to lifting heights up to 3300 mm; specifications for greater lifting heights on request.

* Assumed dimensions

- For greater load centers, where the lift truck has a higher residual load capacity than the attachment, those values, upon the exceedance of which the attachment would be overloaded, are indicated in brackets ().

Pallet Inverters with Load Pusher

2 hydraulic functions + solenoid valve

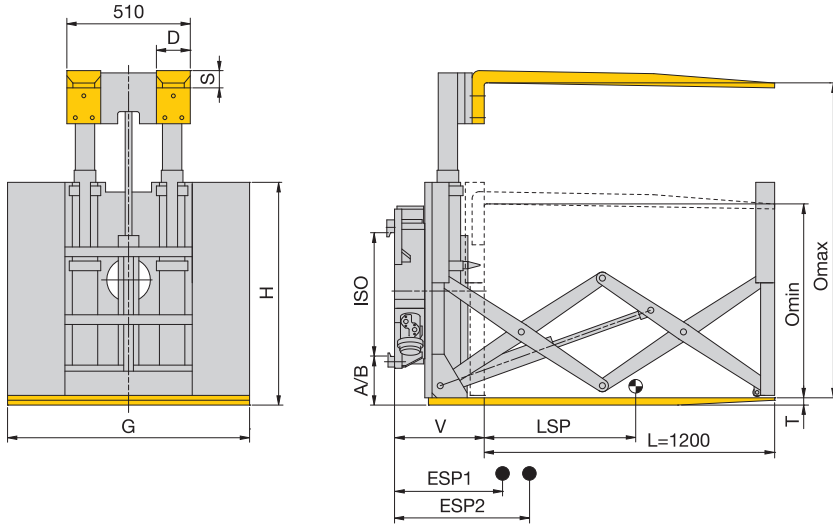

Pushing length 1200 mm · Incl. solenoid valve · Rotation range 360°

Model	Load capacity	LC (LSP)	ISO	Omin-Omax	G	D	S	H	T	V	CoG 1 (ESP 1)	CoG 2 (ESP 2)	Weight	Price	Surcharge per 100 mm add. opening range
	kg	mm		mm	mm	mm	mm	mm	mm	mm	mm	mm			
S 22 - PWG 15-360°-A	1500	500	2/3	800-1300	1000	140	50	920	30	360	380	500	1290		

- Surcharge for adjustable pressure relief valve on request.
- Surcharge for pressure gauge on request.
- Surcharge for lateral support plate on request.

- The opening range is measured at the fork back. Due to a prestress the opening range between the fork tips is correspondingly smaller.

Standard values for residual load capacity of lift trucks**

Pallet Inverters	S 22 -	PWG 15-360°-A	PWG 15-360°-A
Load capacity lift truck	kg	2500	3000
X*	mm	450	450
LC (LSP) = 500 mm	kg	1140	1510
LC (LSP) = 600 mm	kg	1050	(1370)

** The load capacity applies to lifting heights up to 3300 mm; specifications for greater lifting heights on request.

* Assumed dimensions

- For greater load centers, where the lift truck has a higher residual load capacity than the attachment, those values, upon the exceedance of which the attachment would be overloaded, are indicated in brackets ().